

Zebra

Model & Diagram
Jens Kober, 2011

Use a paper 15x15cm or larger.
This model was designed for a paper
with a zebra pattern.

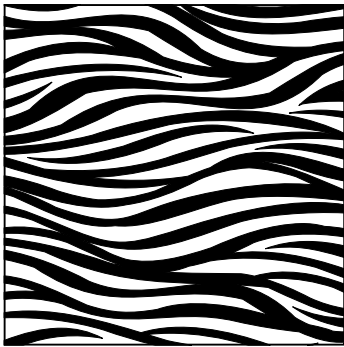
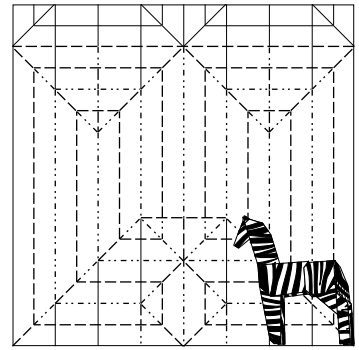

1. Start with the patterned side up, the stripes aligned horizontally.

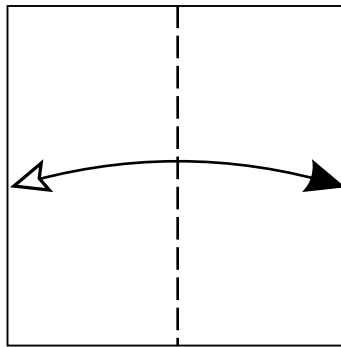

2. Fold the paper in half vertically and unfold.

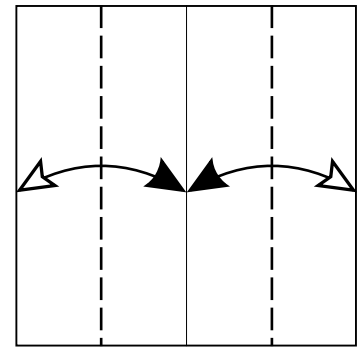

3. Fold the sides to the center and unfold.

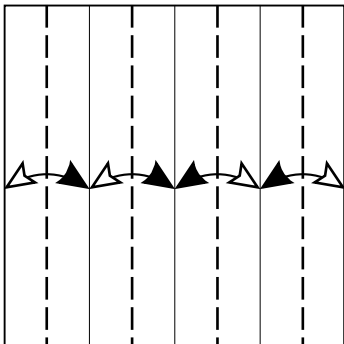

4. Divide the paper into eights.

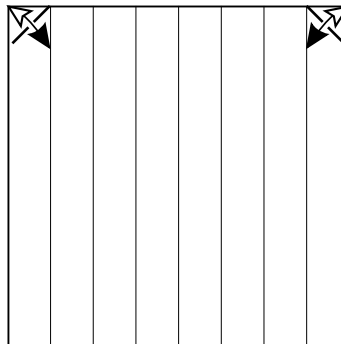

5. Fold and unfold diagonals in the upper corners.

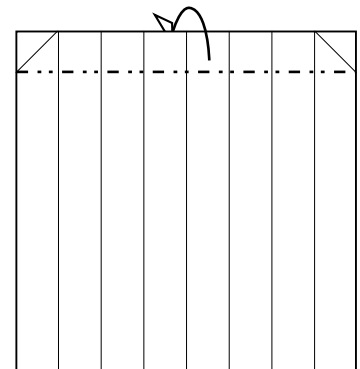

6. Fold the upper eights of the paper behind using the diagonal creases as references. This part of the paper is unused, you can also cut it away.

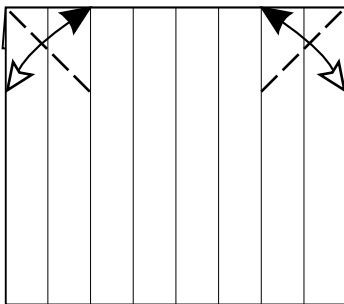

7. Make two diagonal creases at the top.

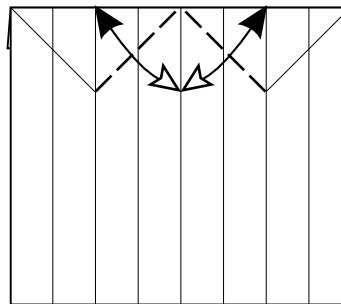

8. Add two more diagonal creases at the top.

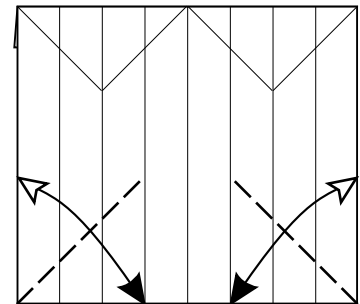

9. Make two diagonal creases at the bottom.

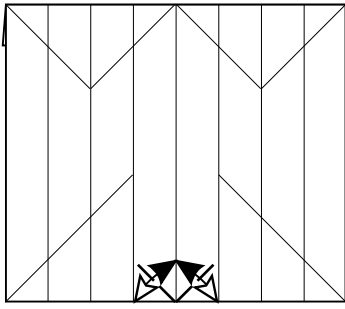

10. Make two small diagonal creases at the bottom.

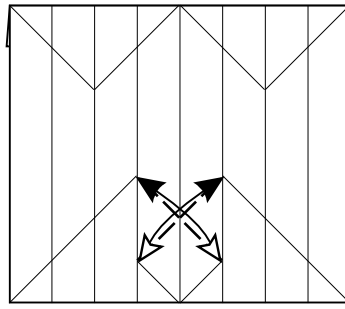

11. Make two more diagonal creases in the center.

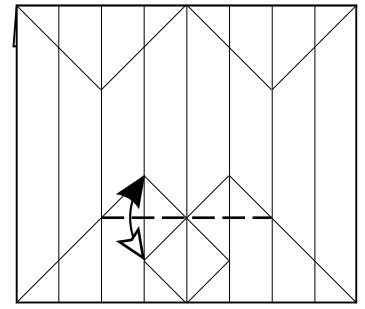

12. Fold and unfold using the diagonals as references.

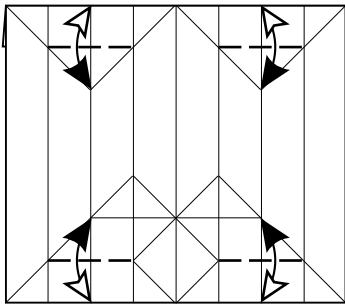

13. Fold and unfold using the diagonals and vertical creases as references. Turn over.

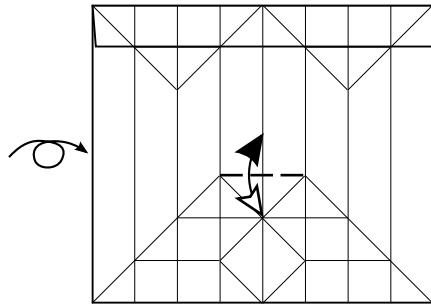

14. Fold and unfold using the diagonals as references. Pre-creasing on the 8th grid done.

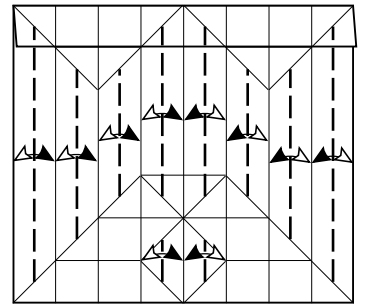

15. Divide some vertical sections in halves always stopping the crease when it hits a diagonal one.

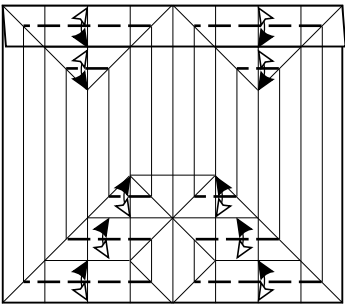

16. Divide some horizontal sections in halves always stopping the crease when it hits a diagonal one.

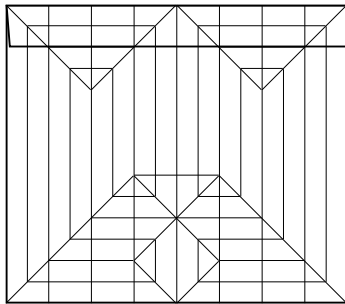

17. All pre-creasing done.

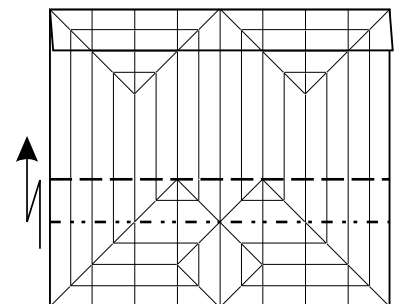

18. Pleat the model on the indicated lines. Do not crease sharply where there are no existing creases!

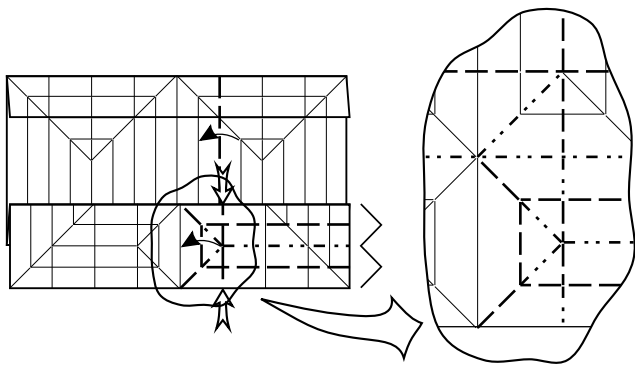

19. Fold the right part in a 90° angle while pleating the bottom part as indicated. The enlarged view shows the unfolded paper. The model will not lay flat. Do not crease the extensions of existing horizontal creases sharply.

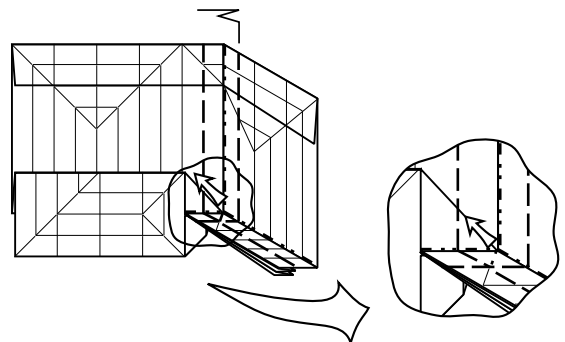

20. Push in the corner (this is a closed sink if seen from behind) while adding some pleats. Until the collapsing of the base is done do not add any new sharp creases.

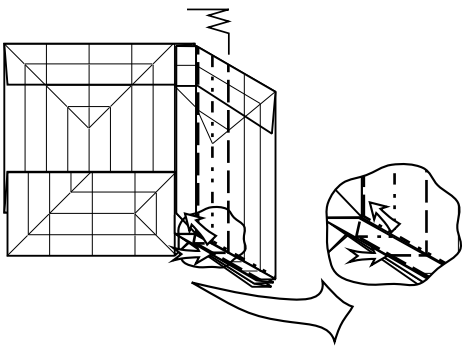

21. Push in and out to form the next pleat.

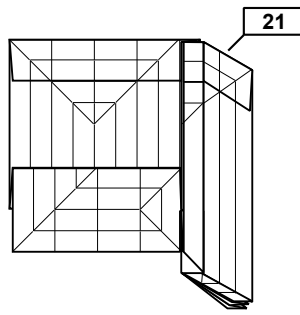

22. Repeat step 21 on the remaining paper and flatten the model.

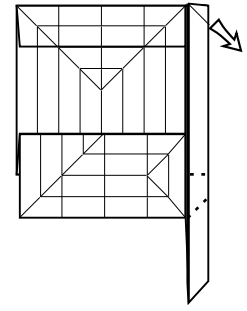

23. The X-ray lines indicate a hidden flap that should have formed. Open the top part of the pleats.

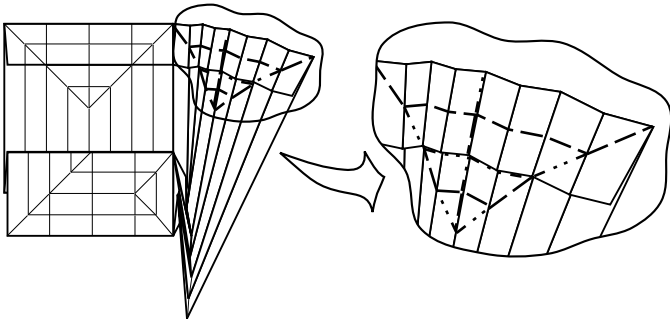

24. Close the pleats again while incorporating the shown folds. This is an Elias stretch.

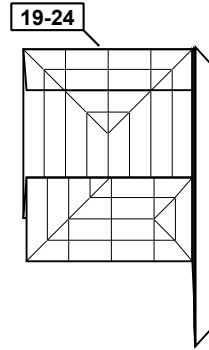

25. Repeat steps 19-24 on the left side. This is the completed base. You should have 3 flaps of equal length at the top as well as 2 long, 1 short and 1 hidden flap on the bottom. Turn the model over. Fold in half and rotate 90°.

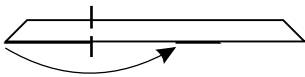
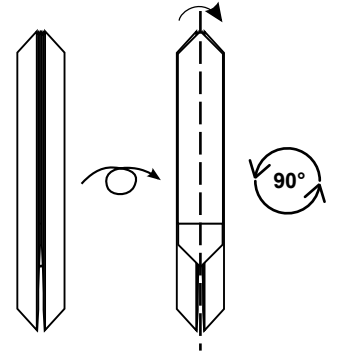

26. Fold the top left flap to the right as far as it will go.

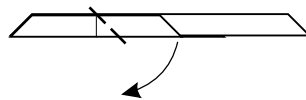

27. Fold the same flap down at 45°.

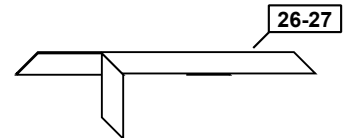

28. Repeat steps 26-27 on the top right flap.

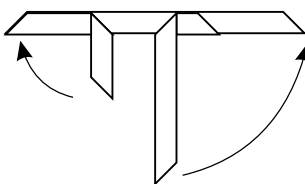

29. Unfold to step 26.



30. Pull the first layer downward. The model will not lay flat.

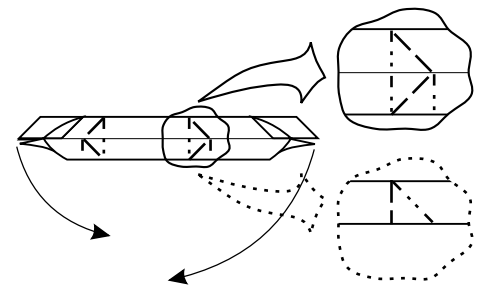

31. Incorporate the shown folds to swing the legs back down. Enlargements: upper=top layer; lower=other (hidden) layers

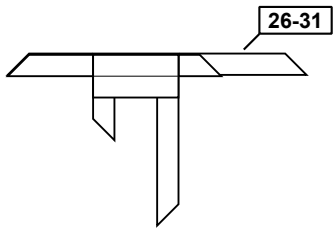

32. Repeat steps 26-31 on the backside.

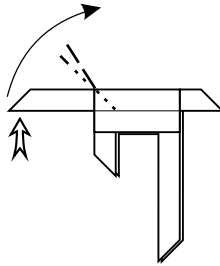

33. Rotate the neck 90° with an inside reverse fold.

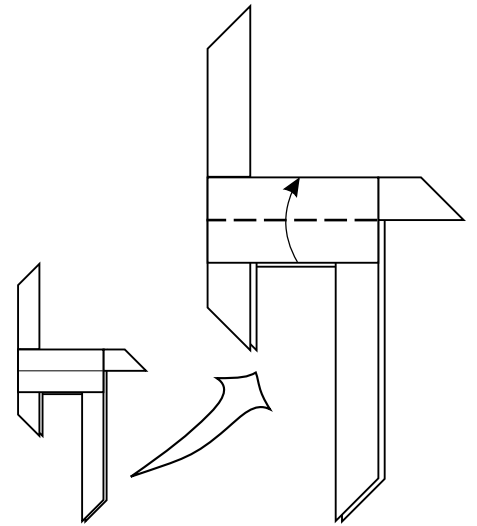

34. Enlarged view. Fold the belly back up along the existing crease.

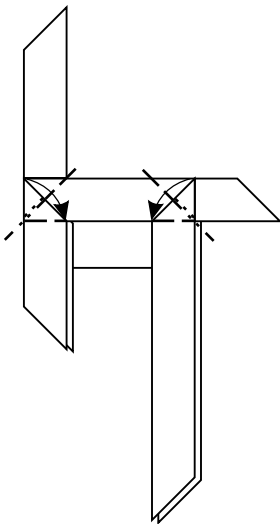

35. Swivel the paper to round the belly by opening out the triangular pockets downward.

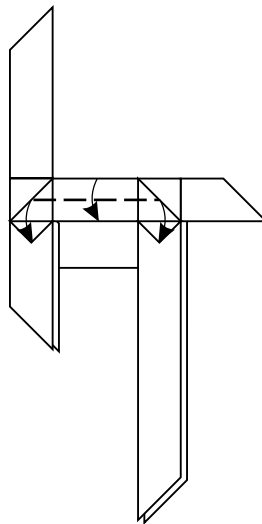

36. Fold the flap in half and back down.

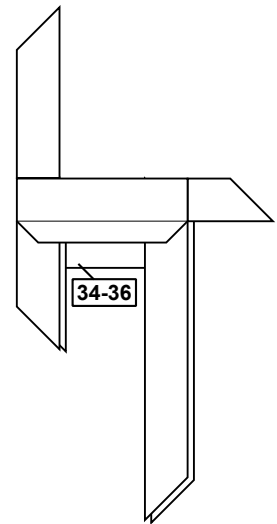

37. Repeat steps 34-36 on the backside.

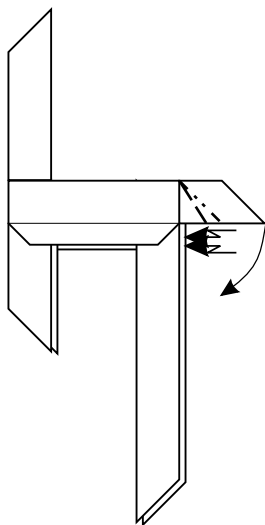

38. Crimp the tail downward.

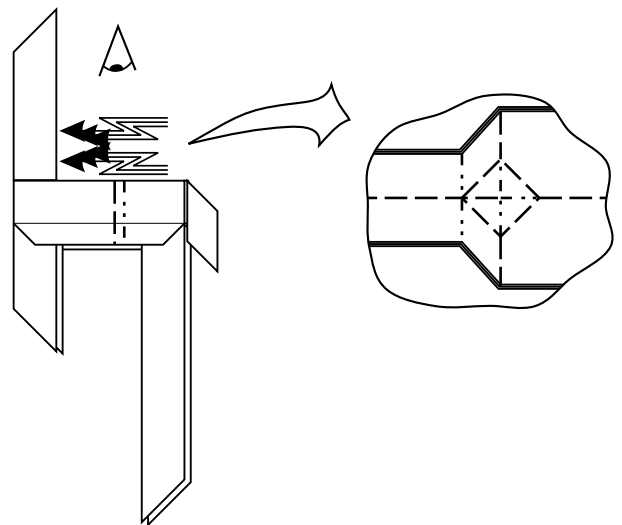

39. Crimp the body while adding the creases indicated in the enlargement to the inner layers. It helps to hold the model directly left to the crimp and to push up the inner layers between the hind legs from below.

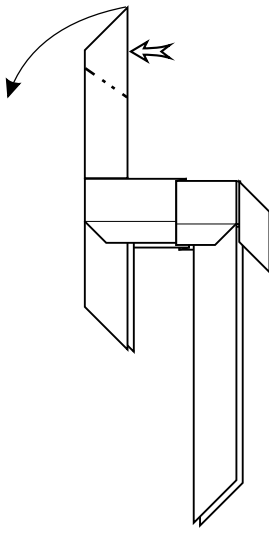

40. Inside reverse-fold the head.

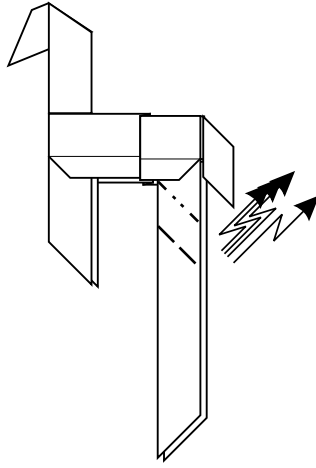

41. Crimp the hind leg. This fold is asymmetrical as indicated by the arrow.

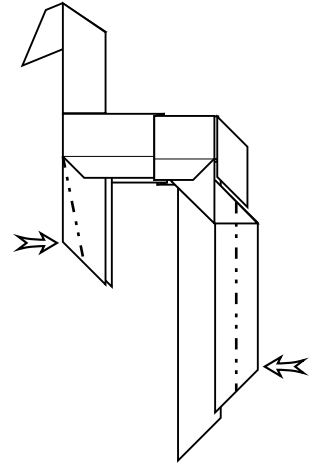

42. Closed sinks to narrow the legs. Also these folds are asymmetrical.

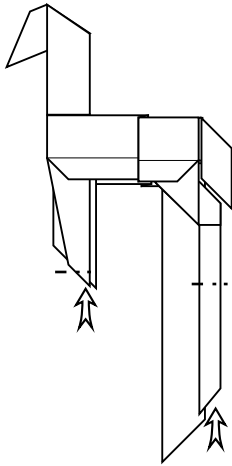

43. Inside reverse-fold the legs to approximately the same length. Again this will be asymmetrical.

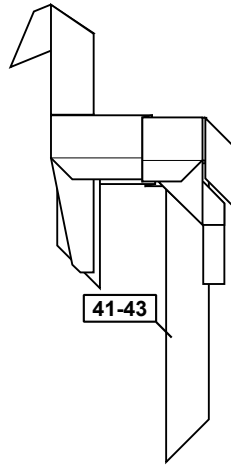

44. Repeat steps 41-43 on the other legs.

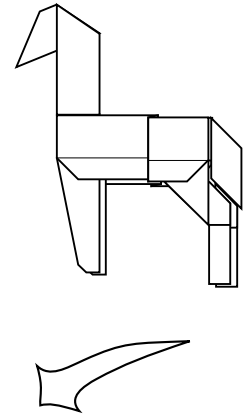

45. Enlarged view.

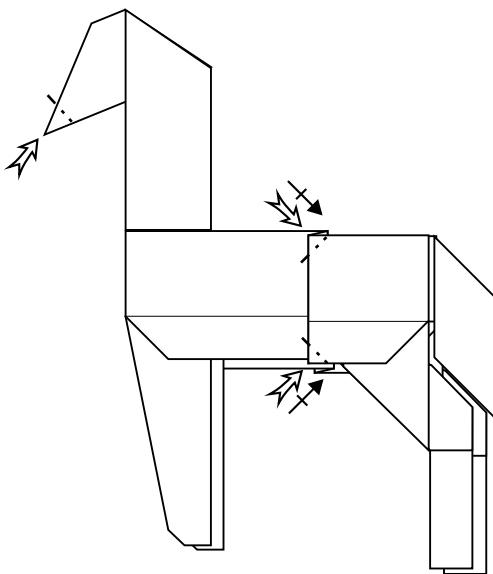

46. Inside reverse-fold the tip of the head. Add some small inside reverse folds to round the hind legs.

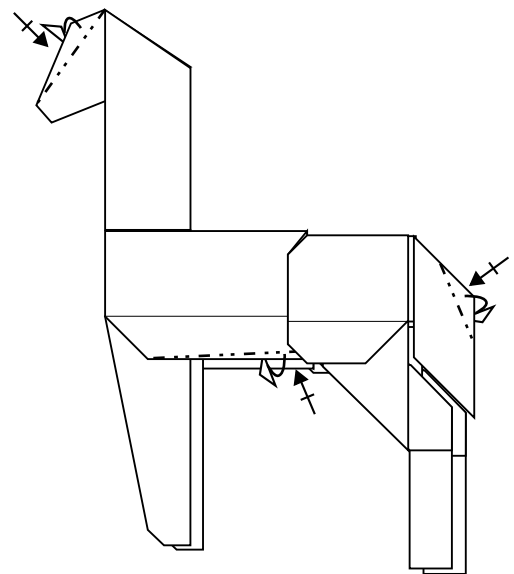

47. Add some mountain folds to shape the head, belly, and tail.

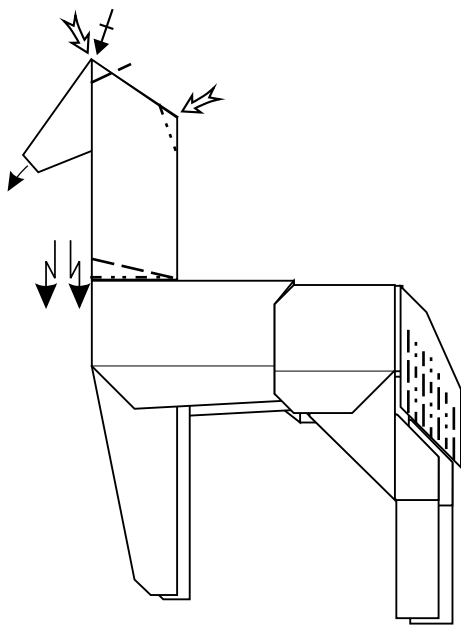

48. Crimp the neck slightly downward. Sink the corner on the neck. Open the ears slightly. Pleat the tail.

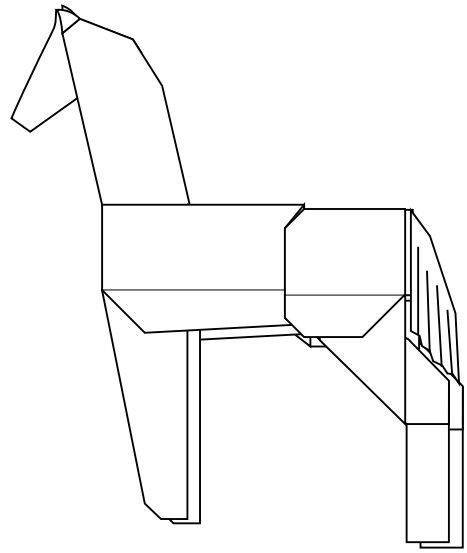

49. This is the finished model. If you used a patterned paper the stripes should be aligned roughly as shown below.

